



KINSHOFER GROUP

[KINSHOFER.COM](https://www.kinshofer.com)

2024



▶ OUR GROUP

Founded as a small business in Bavaria, Germany, in 1971 by Alfred Kinshofer, the Kinshofer Group has grown to become a global leader in the Construction & Landscaping, Demolition, Recycling & Scrap, Railway Maintenance, Material Handling, Foundation & Drilling industries, Forestry and Mining.

Firmly established as specialists within these eight industries, and recognised as being at the forefront of the design and manufacturing of attachments for construction machinery - the Kinshofer Group is home to 12 specialty industry brands, with 24 companies across 13 countries, housing over 4,500 products. With only proprietary product, the Kinshofer Group is the full-liner in the crane and excavator industry giving the Group full control over all processes.

Driven to improve efficiency and productivity to keep our customers moving, each of our brands relentlessly focus on leading the way in innovation to provide superior products.

And, within each of our eight industries, we work tirelessly with our clients to provide logistical solutions and end-of-life product support.

SIMPLY MOVE THE WORLD

▶ OUR BRANDS



24 companies, 12 brands, more than 4,500 products

▶ OUR INDUSTRIES

Our Group strives to innovate and improve customer efficiency and productivity within eight industries.



▶ OUR HISTORY



1971 - 1974

August 4th, 1971, Alfred Kinshofer founded KINSHOFER Maschinenbau GmbH in Miesbach, Bavaria, Germany. The small business started off producing bridge bearings, handrails and accessories for brick factories.

- ▶ In 1973, the development of the first brick stack grapple began.
- ▶ The construction of a pallet fork and a clamshell bucket followed in 1974.



1975-1980

As the capacities of the original factory had been exhausted, a new plant was built in eastern Miesbach in 1975. Only two years later, this building had grown too small again, and a second building was constructed with additional office space.

- ▶ The first rotator with 360° endless rotation was developed in 1975.
- ▶ In 1980, the company changed its name to KINSHOFER Greiftechnik GmbH.
- ▶ The first sales activities in the United States and the UK also took place.



1984 - 1988

The first foreign sales subsidiary KINSHOFER UK Ltd was founded in Stockport, Cheshire, England in 1984.

- ▶ In 1987, Alfred Kinshofer sold his shares and remained as a worthy consultant for the company.
- ▶ The same year, KINSHOFER France was founded in Strasbourg, France.
- ▶ One year later, the planning of the new production plant and office buildings in Marienstein, Bavaria, took shape.



1990-2006

In 1990, construction started on the new plant and buildings in Marienstein, and in December the same year, the company moved into its new buildings.

- ▶ Construction planning of the factories in the Austrian village of Gmünd and the Czech Republic, Ceske Velenice commenced in 1997.
- ▶ In 1998, MARS Greiftechnik GmbH and KINSHOFER CZ s.r.o. was founded.
- ▶ The patented HPXdrive was developed in 2001.
- ▶ In 2006, the company name KINSHOFER GmbH was born; and DEMAREC B.V. was acquired.
- ▶ In 2008, KINSHOFER acquired the Canadian company LIFTALL which became KINSHOFER North America.



2007 - 2018

The Swedish company LIFCO AB acquired KINSHOFER GmbH in 2007.

- ▶ Darda KINSHOFER Construction Machinery Co. Ltd. was founded in 2008 in Beijing.
- ▶ In 2011, KINSHOFER acquired Swedish company, RF-SYSTEM AB.
- ▶ In 2013, the KINSHOFER US-factory opened in Sanborn in the state of New York.
- ▶ Further broadening the product range, KINSHOFER Group acquired AUGER TORQUE Europe Ltd. and AUGER TORQUE Australia Pty Ltd in 2015.
- ▶ In 2017, the KINSHOFER Group acquired SOLESBEE'S Equipment & Attachments in the United States, as well as the New Zealand and Australian based DOHERTY Engineered Attachments.



2019-2024

KINSHOFER grew stronger with clever acquisitions over these years.

- ▶ Along with a further acquisition of Italy based, HAMMER in 2019.
- ▶ In the same year, the administration of KINSHOFER GmbH moved to Holzkirchen, Bavaria.
- ▶ In 2021, the Italy based company CANGINI Benne S.r.l. was acquired.
- ▶ In 2022, the Italy based company TREVI Benne S.p.A., as well as the UK company Prolec Ltd. were acquired.
- ▶ In 2023, the German company HGT GMBH was acquired.
- ▶ In 2024, the Dutch company EUROSTEEL B.V. joined the KINSHOFER Group.



KINSHOFER
crane and excavator attachments



VIEW WEBSITE

VIEW OUR FULL RANGE OF ATTACHMENTS:
KINSHOFER.COM



▶ DELIVERING GLOBAL EXPERTISE

KINSHOFER Cranes and Excavator Attachments has been a leading manufacturer of key industry attachments to customers worldwide. Located in the Bavarian village of Holzkirchen, Germany, our global headquarters offer an extensive range of attachments for equipment carriers with and without hydraulics, covering the scrap, demolition, railway, landscaping, construction, snow clearing, excavating, road building, forestry, tire recycling and biomass industries.

The ongoing demand for transport and infrastructure solutions drives our product innovation and the services we provide; as a result, we continuously expand our product range to develop and produce technical highlights within the industry. The cylinderless and low-maintenance techniques used for the HPXdrive on Grabs, or for NOX Tiltrotators, TC Tilt Couplers and RC Rotary Couplers are just a few examples of these innovations.

With high quality, diversity and using our latest technologies, KINSHOFER Cranes and Excavator Attachments set the standard in the global market.

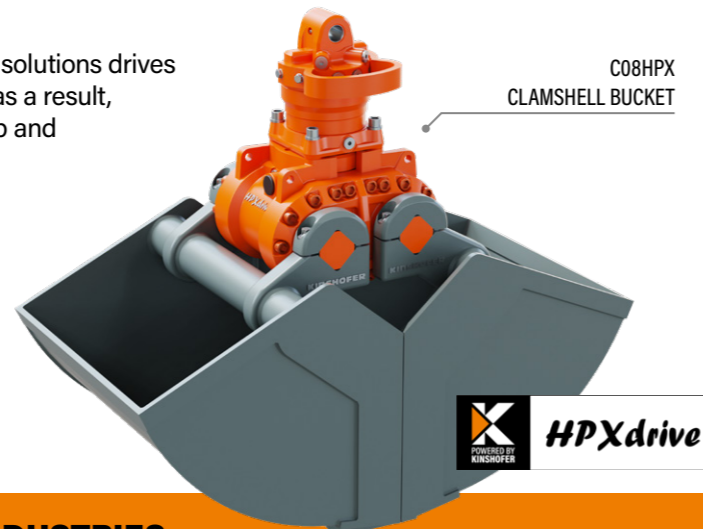

NOX TILTROTATOR

One of the most advanced tools for excavators, the NOX Tiltrotator has a 360° continuous rotation and tilting angles of up to 2 x 50°. With no cylinders and sizing available for 2.5 t to 25 t operating weight, the German-made NOX is an exceptionally universal and multifunctional all-rounder.

This flexible tool is extremely service friendly with only two greasing points and less wear parts. The hydraulics are integrated into the solid cast housing and allow for ease of installation. Extremely wear resistant, the worm gear has its own lubrication providing lower maintenance.

The cylinderless solution features a compact design with narrow width and no protruding parts. The patented tilting function is provided by the elliptic piston design with only one thread. Due to the closed system, the risks of damage are reduced, and the tilting force is constant.

All NOX models can be equipped with the Kinshofer L-Lock, S-Lock and D-Lock quick couplers. Other quick coupling systems are also available. Fully hydraulic quick coupling is also possible with the new Kinshofer SmartFlow for Pin-to-Pin quick couplers but also with the widely applied QilQuick System.

ROTATION & TILT SENSORS

- Geometry overview • NOXPROP control system + autocalibration
- Support for 2D/3D excavating systems e.g. Leica, Trimble, Topcon & Moba.

LOW MAINTENANCE • LOW OVERALL HEIGHT • HIGH AND CONSTANT TILT FORCE • NO PROTRUDING PARTS • LONG SERVICE LIFE

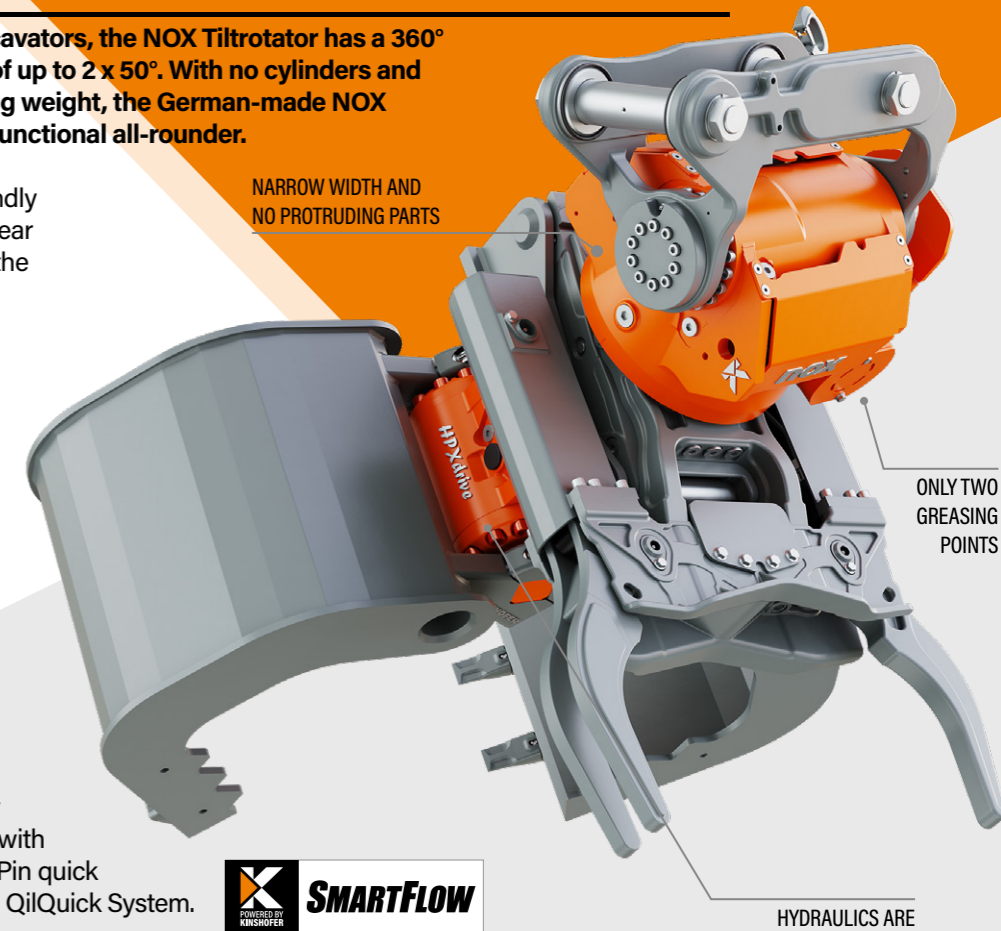

OUR INDUSTRIES





VIEW WEBSITE

VIEW OUR FULL RANGE OF ATTACHMENTS:

DEMAREC.NL



▶ MORE POWER, MORE SPEED, HIGHER PRODUCTIVITY

EXCHANGEABLE WEAR PARTS AND LONGER LIFE TIME

With over 25 years' experience, Netherlands-based DEMAREC has successfully combined market knowledge with technology expertise to deliver quality demolition and recycling equipment worldwide. With a long-life product span, exceptional price/quality ratio, performance and operating costs, DEMAREC provides effective design and excellent service to customers.

Collaborating with end users, we apply their feedback to our product development to ensure we continuously produce superior products. An example of this innovation is the revolutionary DemaPower (2.0) cylinder technology. The DemaPower (2.0) cylinder has four pressure chambers and provides 20-25% more power in combination with the double-acting speed valve, ensuring extremely fast cycle times. The DCC 2-cylinder Concrete Crushers and Mobile Scrap Shears DXS are both equipped with DemaPower (2.0) resulting in performance equivalent to crushers and shears to two sizes up.

MOBILE SCRAP SHEARS (DXS)

The DEMAREC DXS Scrap Shears excel in power and speed along with a favorable weight for best daily performance during demolition and recycling activities. Combined with the DemaPower (2.0) cylinder, the DXS Scrap Shears have more power, more speed and higher productivity.



2-CYLINDER CONCRETE CRUSHERS (DCC)

The DEMAREC DCC 2-cylinder Concrete Crushers have been developed specifically for demolishing thick reinforced concrete, such as viaducts and heavy foundations.

The DCC Concrete Crusher works in combination with the latest model excavators as well as specialized High Reach Demolition Machines.

TWO PIVOT POINTS, ENSURING JAWS HAVE MORE TORQUE TO GENERATE MAXIMUM CLOSING FORCE

IN COMBINATION WITH THE DEMAPOWER (2.0) CYLINDER AND PERFECTLY TAILORED JAW GEOMETRY, DCC CONCRETE SHEARS PRODUCE UP TO 25% MORE FORCE ON AVERAGE THAN SHEARS IN A SIMILAR WEIGHT CLASS



OUR INDUSTRIES





VIEW WEBSITE

VIEW OUR FULL RANGE OF ATTACHMENTS:

RF-SYSTEM.SE



▶ YOUR NEEDS. OUR SOLUTIONS.

RF-SYSTEM develops and markets efficient, versatile tools and products for many categories such as railways, cables and lines, sorting, civil engineering and construction contracting for different carrier machines like excavators, loader cranes and tractors. Our strength is our leading technical skills, continual development of unique, high-quality products, extensive storage, and extremely reliable delivery.

With international expertise and high service characteristics, our strategy is to supply the market with exceptionally well-developed, innovative products that improve efficiency and, more importantly, profitability for our customers. We also undertake special projects where we produce bespoke products to order. All our products are developed for use with a Tiltrotator. Our extensive knowledge and experience from using Tiltrotators in Sweden make us one of the leading companies for these types of attachments.

KPFL CABLE PLOUGH

Front-feed plough with laying tube to minimize bending of cable during laying, it also has a large bending radius, no sharp edges, removable rails for two cable channels, and fixed pipe for ground wires. The standard plough has a width of 95 mm or 130 mm for cable channels.

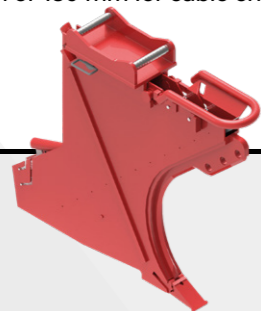

AVB - LEVELLING BEAM WITH ROLLER ACHIEVE PERFECTLY EVEN SURFACE

The Levelling Beam can be supplemented with a Scraper to keep material from sticking to the roller. The roller provides support when titling back or forth. Available in several variants, couplings and widths.



ACCESSORIES: Coupler, slope meter, scraper.

GAH - HYDRAULIC FORK SET

HYDRAULICALLY ADJUSTABLE FORKS

Low weight fork adapted for use with a Tiltrotator. Easy to connect and with a lifting capacity from 1.9 to 5 t. Standard fork length is 1000 mm for 1.9 t and 1200 mm for the rest. Unique steel guards for piston rods. Long stroke length makes it easy to grab goods near walls and similar. Each fork tine can be locked separately to manoeuvre only one fork via hydraulics. Also available in a mechanical version (GAF).



RST BALLAST TAMPER

A tried and tested ballast tamper that fits all excavators and cranes. Ideal for road-rail excavators with 5 – 24 t operating weight, the tamper packs with high frequency and minimal noise levels. The tamper only weighs 640 kg, and has a replaceable adapter and several drive options enabling use on both small and large machines. The tamping depth of the RST is adjustable and the carrier machine benefits from the strong vibration rubbers that reduce the impact on the machine.



OUR INDUSTRIES





▶ ULTIMATE IN VERSATILITY

AUGER TORQUE is a global manufacturer and leading provider of earthmoving attachments. With a strong focus on quality, innovation and service, our product range is designed for the construction, agriculture and earthmoving industries, and includes earth drills, augers, screw pile torque heads, mast rigs, trenchers, mulchers, log splitters and stump planers. With five manufacturing facilities, stock holding premises worldwide and a global network of over 150 distributors, AUGER TORQUE meets the needs of all global markets quickly, robustly and cost effectively.

EARTH DRILL

Built to exacting standards, our range of hydraulic earth drills with planetary gearbox use only high-quality materials and the latest manufacturing techniques. Suitable for a range of parent machines such as excavators, skid steer loaders, telehandlers, backhoes, truck cranes and mini loaders from 750 kg through to 45 t machines. With the ultimate in versatility, the earth drill can be used with a range of AUGER TORQUE attachments.



AUGERS

Our Augers are built from high grade steel allowing you to work more efficiently and easily, designed to ensure drilling is undertaken with maximum efficiency. The range is vast and suitable for excavators, skid steer loaders, truck cranes, backhoes and telehandlers. Different tooth options available for various soils and conditions as well as a range of standard or telescopic auger extensions.



VARIABLE MULCHER

Suitable for excavator and skid steer loaders, the Variable Mulcher provides a working width up to 1.5 m and has the unique time-saving feature of being able to change the whole tooth drum instead of individual teeth.



TRENCHER

Our trenchers cover depths of up to 1.5 m and widths up to 350 mm, whilst spoil is piled neatly to the side of the trench by the integral Auger. With high quality hydraulic motors and planetary gearbox, our Trenchers have the reliability and power to ensure trenching is carried out with ease.



OUR INDUSTRIES

CONSTRUCTION & LANDSCAPING

DEMOLITION TASKS

FOUNDATION & DRILLING



▶ QUALITY THAT GIVES YOU CONTROL

Based in Winston, Atlanta GA, SOLESBEE'S Equipment and Attachments LLC is a full-service, heavy equipment manufacturer offering high-quality, standard and custom attachments for every major brand of heavy equipment. In operation since 1993, we offer a complete line of strong and durable attachments for every type of job required by forklifts, bulldozers, front-end and back-end loaders, excavators and tractors.

EXCAVATOR THUMB

Our quality Excavator Thumbs handle everything from stumps, trees, brush, logs, pipe and stone material and are ideal for site-prep, demolition and waste recycling. They can be installed easily by qualified welders in approximately 2 hours, and include all pins and hardware.



FOLDS AWAY, LEAVING NO INTERFERENCE WITH DIGGING AND OTHER OPERATIONS

AVAILABLE FOR ANY SIZE OR MODEL EXCAVATOR

SKID STEER GRAPPLE RAKE

The SOLESBEE'S Skid Steer Grapple Rake is ideal for land clearing and site prep, as well as many other material handling operations.

Tasks to separate and move trees, logs, stumps and brush from all dirt and small rocks are made quick and easy when completed with our Skid Steer Grapple Rake.

Our attachments are job-site ready and designed to maximise your productivity and profits.

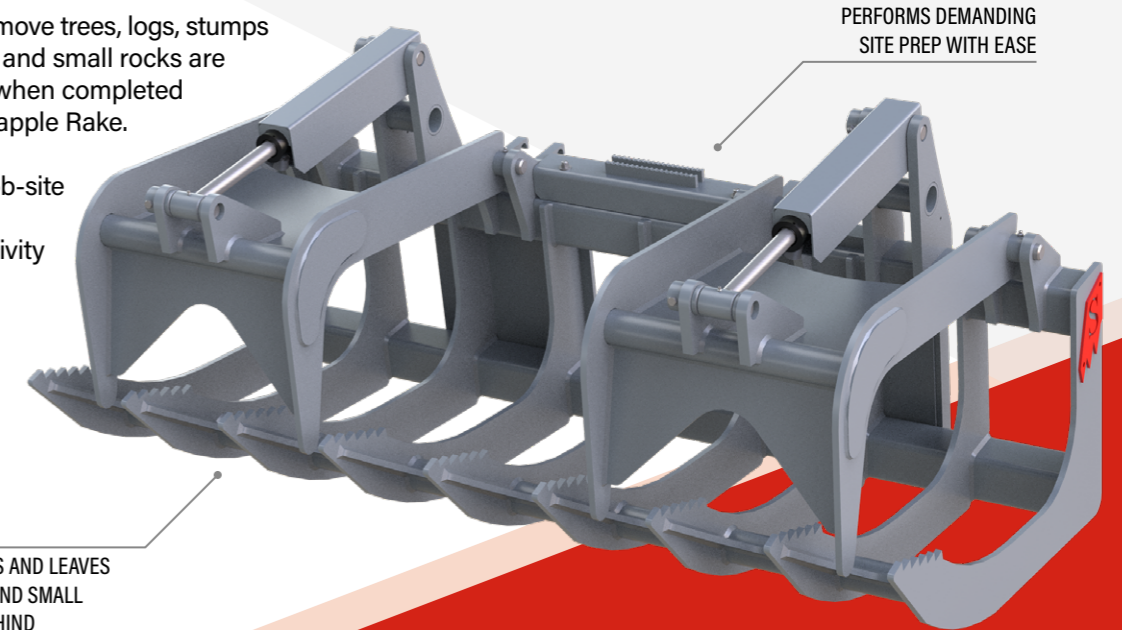

PERFORMS DEMANDING SITE PREP WITH EASE

SEPARATES AND LEAVES ALL DIRT AND SMALL ROCKS BEHIND

OUR INDUSTRIES

CONSTRUCTION & LANDSCAPING

RECYCLING & SCRAP



▶ YOUR COUPLER SPECIALISTS

DOHERTY Couplers and Attachments design and manufacture world-leading, high-quality earthmoving attachments for the construction, demolition, quarrying and mining industries worldwide. Dedicated to safety and quality, we lead the way in attachment innovation and are one of the few manufacturers globally to offer fully automatic quick couplers 100% compliant to AS4772-208, EN474 and ISO13031 standards, and major contractor policies. Our key products include the D-Lock and D-Lock Tilt Couplers:

D-LOCK COUPLER

Compact in design with only two hoses, minimal moving parts, no greasing and no complicated operating sequence, the D-Lock Coupler is testament to our continuous focus on improvement.

With the D-Lock's patented Dual Pin Locking (DPL) system, attachments remain securely engaged on both pins in the event of loss of engagement force.

Its simple design, combined with world-leading safety features makes the D-Lock the safest coupler on the market today, and places it at the forefront of coupler performance worldwide.

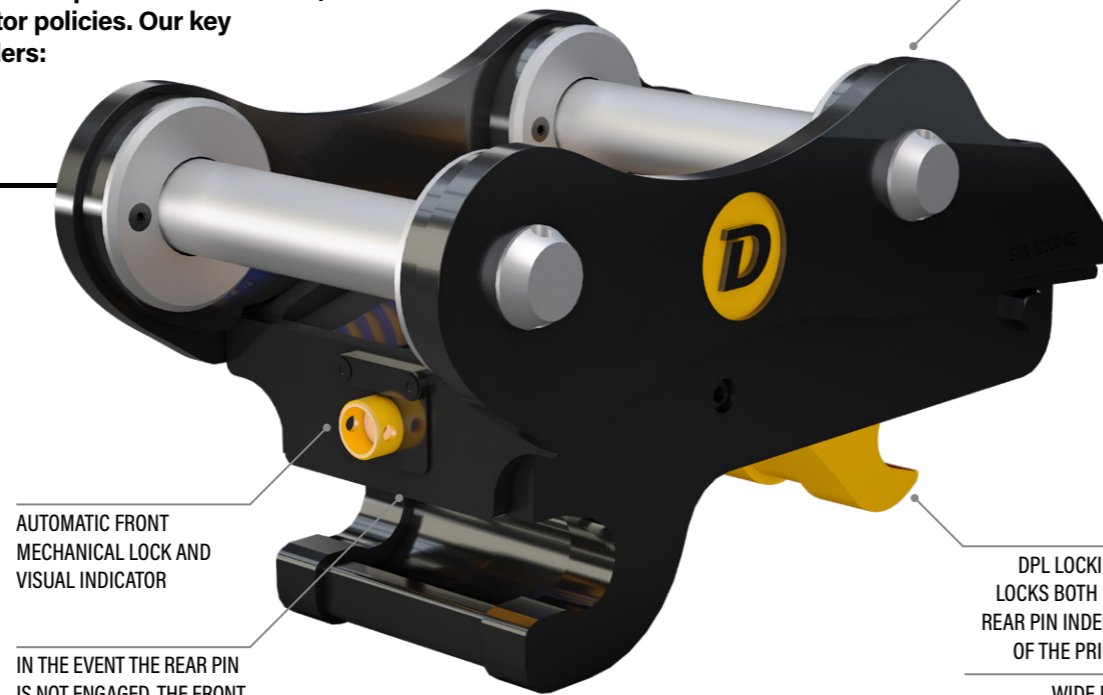

AUTOMATIC FRONT MECHANICAL LOCK AND VISUAL INDICATOR

IN THE EVENT THE REAR PIN IS NOT ENGAGED, THE FRONT PIN REMAINS LOCKED

DPL LOCKING SYSTEM LOCKS BOTH FRONT AND REAR PIN INDEPENDENTLY OF THE PRIMARY LOCK

WIDE PIN CENTRE PICK UP RANGE

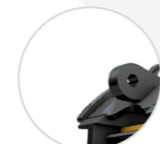

CERTIFIED LIFTING EYE

D-LOCK TILT COUPLER

When productivity is paramount demand the D-Lock Tilt.

Compact in design, powerful and virtually maintenance free, the D-Lock Tilt Coupler incorporates a precision-built actuator ensuring trouble free operation.

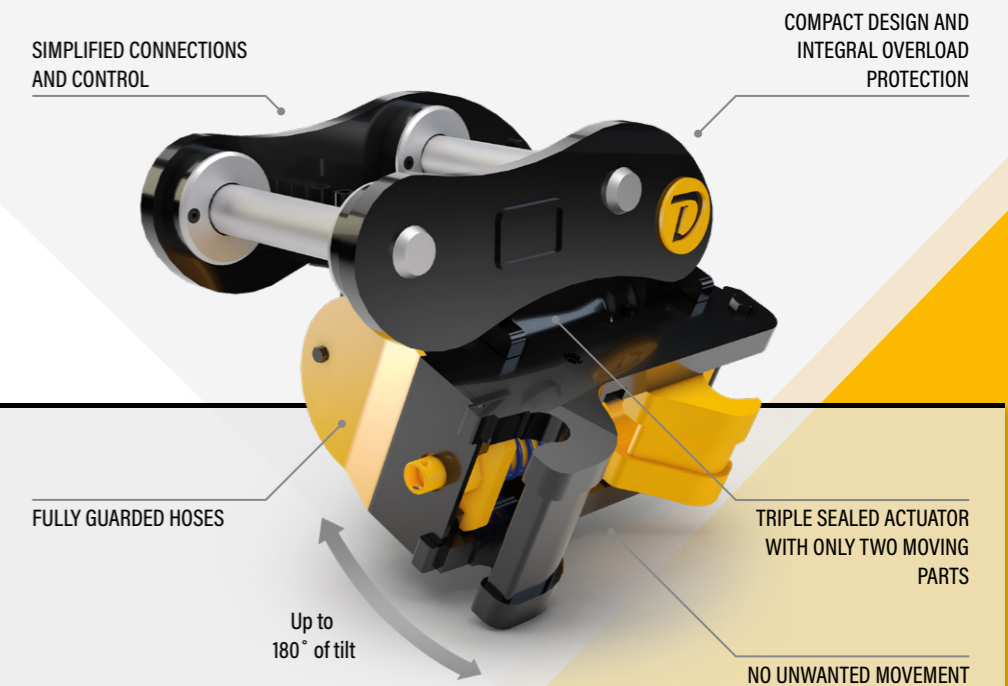

SIMPLIFIED CONNECTIONS AND CONTROL

COMPACT DESIGN AND INTEGRAL OVERLOAD PROTECTION

FULLY GUARDED HOSES

TRIPLE SEALED ACTUATOR WITH ONLY TWO MOVING PARTS

Up to 180° of tilt

NO UNWANTED MOVEMENT

The D-Lock is standard on the D-Lock Tilt and available for use on all Tiltrotators.

OUR INDUSTRIES

CONSTRUCTION & LANDSCAPING

DEMOLITION TASKS

RECYCLING & SCRAP

RAILWAY MAINTENANCE



▶ ITALIAN DESIGN AT ITS BEST

Located in the industrial area of Molfetta, Bari, HAMMER guarantees the highest quality, Italian designed and manufactured hydraulic breakers, hydraulic crushers, shears and other attachments. Hammer manufactures more than 95% of its components and products in house with a highly sophisticated and extremely modern machine plant consisting of more than 65 CNC machines.

Our high performing and powerful hydraulic breakers have been developed with in-depth R&D studies carried out over 30 years. The demolition segment also includes our FP series - fixed hydraulic crushers for secondary demolition, the FR series - rotary hydraulic crushers for primary and secondary demolition; and the introduction of the SB and FX lines - hydraulic breakers for primary demolition. Our latest grapple line of the GR series, includes nine models for excavators with operating weight from 1.5 to 80 t. Firmly established in the global market with 10 branches spread across the continents and a capillary network of dealers and authorized workshops throughout the world, HAMMER paves the way for the demolition and recycling industries.

FR SERIES CRUSHERS

Rotary crushers for primary and secondary demolition with jaws designed for each application area. 11 models for excavators with operating weight from 1.5 to 90 t.

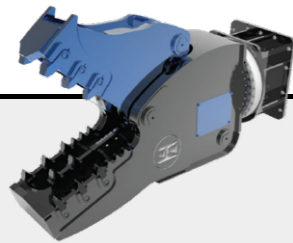

DEMOLITION AND SORTING GRABS

Robust and multi-purpose, our GR Series excavator grabs have fully integrated rotation with sturdy slewing ring to withstand external forces.

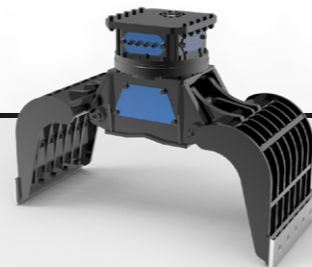

MONOBLOC HYDRAULIC BREAKERS

With its closed box casing and the insertion of sound-absorbing material, our SB series has very low noise levels.

The SB Series tolerate high back pressure values and with a wide calibration range of oil flow, the entire Series benefits from monobloc construction giving very high resistance to leverage during work. Their tapered shape provide an excellent view during work and allow operators to work close to walls in narrow sections and with open front. The breakers work with inertial nitrogen energy recovery, obtaining more than 30% more power and less vibration thanks to the nitrogen chamber.

With no diaphragms inside, and with the breakers built as one piece without tie rods, it reduces maintenance and offers more production for our customers.

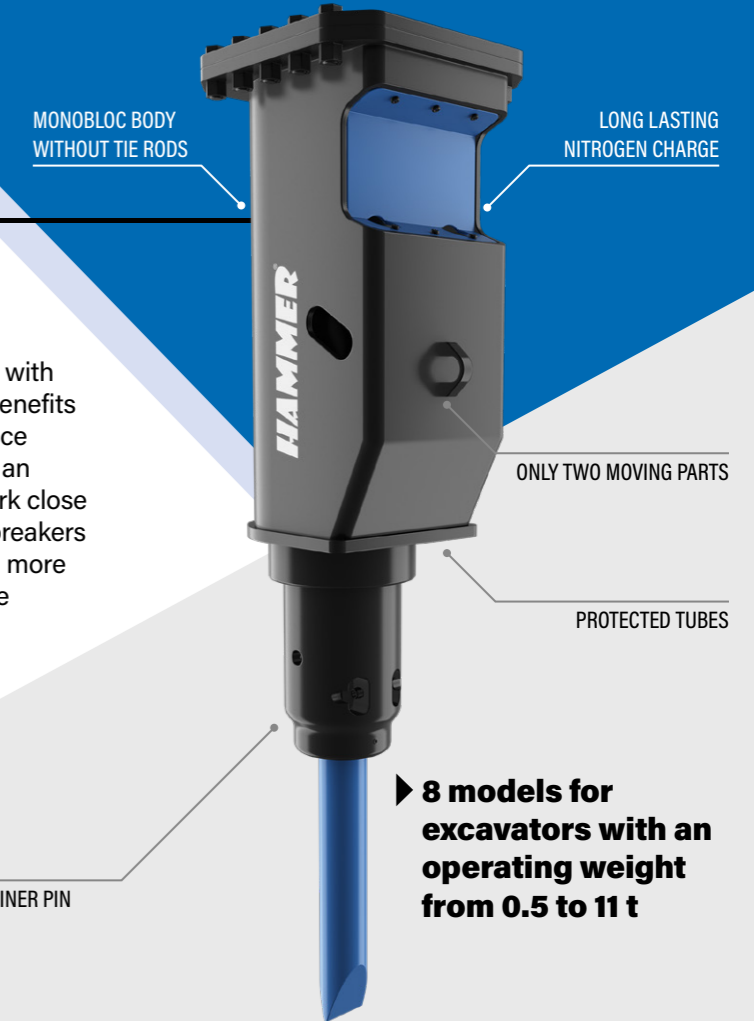

▶ 8 models for excavators with an operating weight from 0.5 to 11 t

OUR INDUSTRIES





PASSIONATE TOOLS

Based in Sarsina in the North Italian region of Emilia-Romagna, CANGINI stands in Italy for high-quality and long-term proven attachments for excavators and loaders. Cangini produces 100% of the products in Italy and cultivates excellence in staff, products and processes - with no compromise.

We invest most of our project resources in Research & Development: here our design, engineering and specialized technicians team cooperates to design the safest and most reliable new equipment, and to improve our already existing technology. This is also possible thanks to constant feedback from our dealers, rental companies and final users. We design our projects according to the final user's needs. Safety is our priority, and we always commit to supplying safe and long-lasting attachments to our customers. We work in strict compliance with the Machinery Directive:

- > All attachments are designed and built following risk analysis and the relevant corrective actions.
- > Our Use and Maintenance Manuals are clear, detailed and structured for easy consultation: they are divided into installation, safe usage, functioning and maintenance sections.
- > In order to ensure machinery absolute safety and safe operation, we specify the intended purpose of each product.

ATTACHMENTS FOR EXCAVATORS

One of the most complete assortments ever. Cangini's design and manufacturing quality, for tackling any on-site work.

ATTACHMENTS FOR LOADERS

Attachments for front coupling, a wide range of high-performance tools.



FORCE ONE FORESTRY MULCHER

The forestry mulcher is designed to handle even the heaviest workloads: the deep clearing of woods and forests.

It is equipped with a piston engine to withstand the most intense work pace.

It can be equipped with different rotors to suit any need. The forestry rotor with retracting hammers is suitable for cutting shrubs, bushes and briars. The forestry fixed-tool rotor is designed for heavy-duty works, such as mulching large sized plants. The chipping rotor is suitable for grinding trunks.

The power of the different rotors can be better exploited thanks to the presence of back and front opening hoods. The great resistance of the forestry mulcher is guaranteed by its reinforced body.

Another feature that makes this equipment extraordinary is the forced ventilation operated directly from the rotor, which allows the cooling of circuits and of the hydraulic motor, in order to keep oil temperature constant.

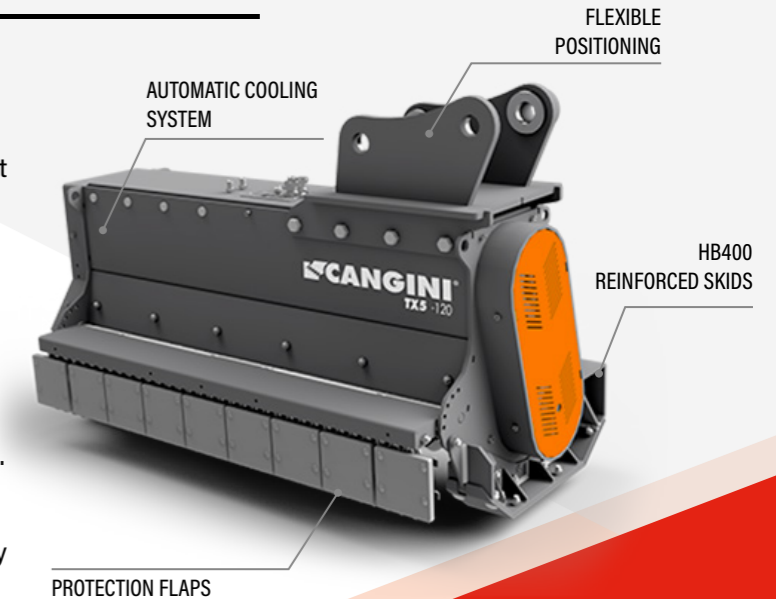

► **5 models for excavators with an operating weight from 8 to 20 t**

OUR INDUSTRIES





▶ QUALITY WITHOUT COMPROMISE

Based in Noventa Vicentina, Italy, Trevi Benne is working in over 50 different countries with a network of professional dealers. It is a TÜV certified company that stands for quality and is also an active sponsor of the major associations of national and European demolition companies.

Since 1992, Trevi Benne has been manufacturing and marketing technology and equipment for earthmoving machinery, featuring three main product lines: demolition and recycling tools, buckets (including large, heavy-duty mining buckets) and forestry equipment.

Demolition and Recycling

Shears, Pulverizers, Breakers and Demolition and Sorting Grapples for primary and secondary demolition.

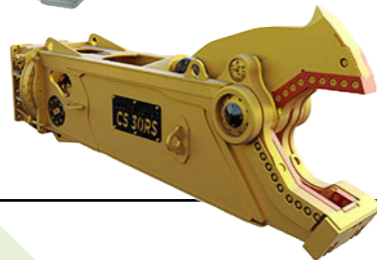
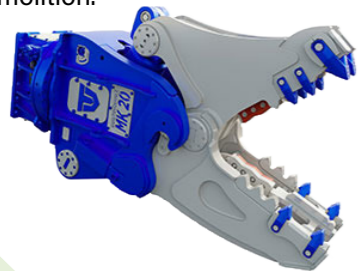

Excavator and Loader Buckets

Complete range of standard and reinforced buckets, also as special version with anti-wear finish and increased thickness, for excavation and mining tasks for excavators with up to 500 t operating weight.



HARVESTER TREE SHEAR

Designed for cutting and harvesting wood on a large scale, for the felling of unsafe trees, for cultivation and landscape care and maintenance works.

Ideal for companies that perform road green maintenance, for reclamation consortia and for industries operating in the ecological sector and for environmental enhancement.

The innovative twin-blade cutting system significantly improves penetration into the material, does not fray the trunk, does not damage the bark and guarantees a clean cut.

The WR series is available with either a heavy duty, high torque 360° twin motor system, or a 2 x 50° pivoting twin cylinder system.



FOR MAX. TRUNK DIAMETERS:
FROM 400 TO 550 MM

▶ **3 models for excavators with an operating weight from 12t to 35t**

UNSERE BRANCHEN





▶ SIMPLY SAFER



PME100
Height limiter

PME200
Rated Capacity Indicator (RCI)

PME300
Slew limiter

PME400
Height & slew limiter

PME500
Combination of PME100 to PME400

PME700
Monitors stability for long reach booms in demolition projects

Based in Poole in the south of England, PROLEC stands for safety. Safety is the top priority. It's the cornerstone of everything Prolec does. With Prolec you protect your assets, employees and investments reliably and sustainably.

With 40 years' experience supplying machine productivity and safety systems for construction equipment, and a heritage of trust and excellence, Prolec has set the benchmark for compliant, smart solutions.

Our systems meet industry standards, so you can be confident that you'll be equipped to meet the demands of main contractors and clients.

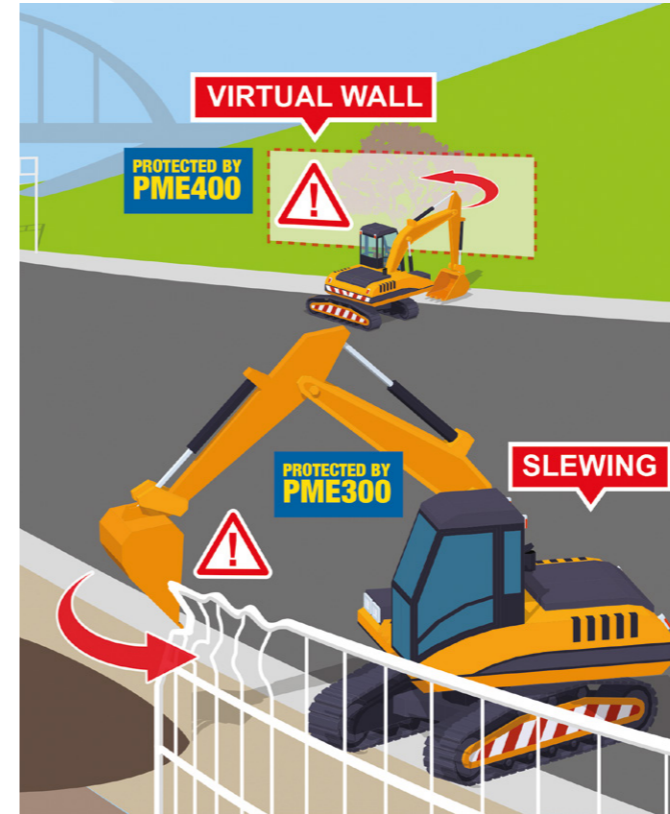

Safety Systems

Our safety systems mitigate the risk of incidents thereby reducing the costs associated with repair, engineer call outs and machine downtime.

Guidance Systems

Work faster with exceptional accuracy to improve the productivity of your operations and all but eliminate the need for costly reworks.

OUR INDUSTRIES





VIEW WEBSITE

VIEW OUR FULL RANGE OF ATTACHMENTS:

HGT-GREIFER.DE



▶ ONE SOURCE FOR THE BEST POSSIBLE EXCAVATOR

THIS IS OUR TEAM'S PROMISE TO YOU

"Hydraulic hands" made for every hydraulic carrier from the mini excavator with the operating weight of 800kg to the 220t material handler. Specially developed hydraulic slewing gears, designed and produced in Peine, between Hanover and Brunswick, form the link between machine and gripper.

As a manufacturer of hydraulic grabs and slewing gears, we develop and produce highly specialized grabs and load suspension devices for miniexcavators from 800 kg to excavators with a service weight up to 400 t. We have been developing our products at the our location in Ilsede nestled between the cities of Brunswick and Hanover since 1986. Our mission is to produce innovations and create products that work as effectively as possible in conjunction with excavators while delivering perfect results. To accomplish this, our design department continuously develops and refines our grabs. We incorporate the insights resulting from the required applications and experiences into our product development.

WOOD LOADING GRABS (TG)

Due to the shape of the tines, TG wood grabs can easily pick up one or more logs of different diameter from the ground, a stack or truck and confidently hold and handle them.

CONTINUOUSLY ROTATABLE HYDRAULIC SLEWING GEAR. MOTOR PROTECTION PLATE FOR THE HYDRAULIC CONNECTIONS ON THE SLEWING GEAR.

TOOTH SEGMENTS OR SYNCHRONIZED CONTROL RUN PROTECTED IN THE ARM. MECHANICAL OPENING AND CLOSING STOPS TO PROTECT THE HYDRAULIC SYSTEM.

- STRAPS, TOOTH SEGMENTS HB 450
- SIDE PARTS S 690 QL
- BOTTOM EDGE HB 500



TWO-SHELL LOADING GRABS (RCS)

Optimized grabs for the transfer of bulk materials such as gravel, sand, pebbles, grain, feed, fertilizer, ore, coal, etc.

OUR INDUSTRIES

- | | | |
|----------------------------|-----------------------|---------------------|
| CONSTRUCTION & LANDSCAPING | DEMOLITION TASKS | RECYCLING & SCRAP |
| MATERIAL HANDLING | FORESTRY APPLICATIONS | RAILWAY MAINTENANCE |



EXPERT FOR QUICK COUPLERS AND ATTACHMENTS FOR EXCAVATORS & LOADERS

Since 1985 we have been developing and producing quick-couplers and equipment for excavators and wheel-based loaders. We aim and work to offer added value for every client, with products that exactly meet each one's specific requirements.

CW QUICK COUPLERS

Eurosteel supplies the widely used, safe and robust CW-quick couplers in all sizes for excavators up to 90 t. We also supply our own S-couplers, for machines up to 30 t.

The low-build, safe and easy to use CW-system is available in sizes ranging from CW00 - CW70, in different versions (mechanical or hydraulic, standard, narrow or extra narrow) and with various options such as a certified lifting hook.

HKO 2000 QUICK COUPLERS

Eurosteel supplies the 2000-System quick couplers in various sizes, suitable for wheel loaders up to 54 t. The 2000-System is characterised by the vertical wedge lock and extremely robust and backlash-free system.

The hydraulically operated, easy to change System 2000 is available in sizes ranging from HKO 2001 - HKO 2111 and is suitable for work tools with 2 hooks.

VISIBLE LOCK

MACHINE SPECIFIC ATTACHMENT POINTS

BACKLASH-FREE DUE TO VERTICAL WEDGE LOCK

MINIMAL LOSS OF BREAKOUT FORCE DUE TO UNIQUE DESIGN

OPTIONAL LOAD HOOK

MACHINE SPECIFIC ATTACHMENT POINTS

ROBUST AND PROVEN SYSTEM

BUCKETS FOR EXCAVATORS AND WHEEL LOADERS

User safety, quality and fast delivery times.

Eurosteel offers a wide range of buckets for excavators and loaders for all conceivable applications, from digging trenches and excavating foundations to finishing slopes. The buckets are available in various dimensions and sizes: small to large and narrow to wide and with an enormous diversity of suspension systems, wear materials and (customer-specific) options.

AVAILABLE WITH FIXED SUSPENSION, OR QUICK COUPLER SUSPENSION SUCH AS THE 2000-SYSTEM, LUNDBERG, IT ETC.

AVAILABLE WITH VARIOUS SUSPENSION SYSTEMS SUCH AS: CW, QUICK-TWIN, S-SYSTEM, FIXED, ETC.



STANDARD BOTTOM WEAR PLATES

EUROTILT TILTROTATORS

Eurosteel Tiltrotators are equipped with hydraulic wedge coupling CW lower quick couplers and available for excavators from 2.5 t up to 25 t.

No hydraulic cylinders!
The tilt is generated by a tilt drive for up to 2 x 50° tilt.
A worm drive generates a 360° endless rotation.

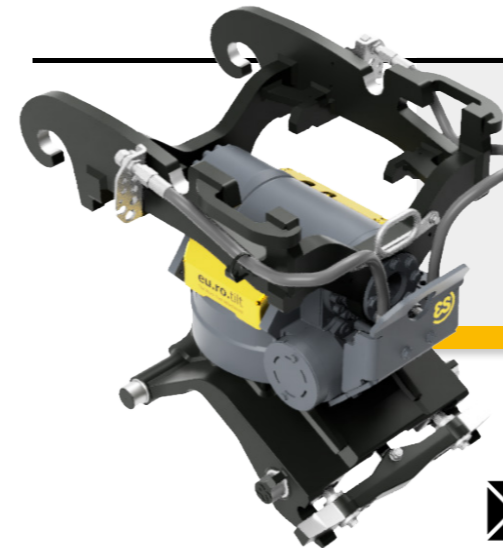

OUR INDUSTRIES

- CONSTRUCTION & LANDSCAPING
- DEMOLITION TASKS
- RECYCLING & SCRAP
- MATERIAL HANDLING

KINSHOFER GROUP

Raiffeisenstrasse 12
83607 Holzkirchen, Germany

Tel. +49 (0)8021 8899 0

Fax. +49 (0)8021 8899 37

Email. info@kinshofer.com

 **SIMPLY
MOVE THE
WORLD**



KINSHOFER.COM
